

**Question 13:** In the Plinko! model of current, if the spacing between the atoms that make up the conducting material increases, what happens?

- A) Current increases because electron density increases
- B) Current decreases because electron density increases
- C) Current increases because the average time between collision increases
- D) Current increases because the average time between collision decreases
- E) Current decreases because the average time between collision increases
- F) Current decreases because the average time between collisions decreases

**Question 14:** You have a cylindrical resistor with resistance made out of silly putty. It starts with length  $L$  and radius  $r$ . You squish the resistor such that it has a new length  $L/2$  and a new radius. If the initial resistance is  $R_i$  and the final resistance is  $R_f$ , what is the ratio of the final resistance to the initial resistance  $R_f/R_i$ ?

- A) 1/8
- B) 1/4
- C) 1/2
- D) 1
- E) 2
- F) 4
- G) 8

**Question 15:** The circuit below starts with the switch open. The switch is then closed. What is the voltage across the 4 Ohm resistor *in series with the capacitor* i) the instant after the switch is closed and ii) after the switch has been closed for a long time?

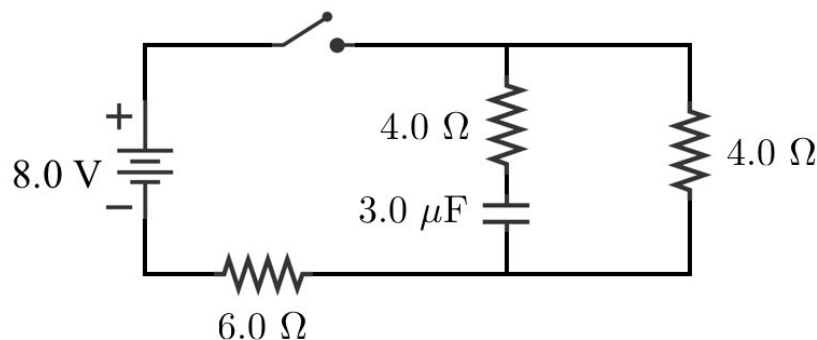

	Instant after switch is closed:	A long time after the switch is closed:
A)	0 V	2.0 V
B)	0 V	3.2 V
C)	2.0 V	0 V
D)	2.0 V	3.2 V
E)	3.2 V	0 V
F)	3.2 V	2.0 V



**Question 16:** The picture above is a top view of two identical permanent magnets, one placed near a compass needle and the other floating freely on a pool of water (so that it is free to rotate). In the picture, which direction is north (i.e. towards the arctic)?

- A)  $\rightarrow$       B)  $\leftarrow$       C)  $\uparrow$       D)  $\downarrow$

**Question 17:** In the picture below, which direction could the positive charge be moving in order to produce the magnetic field at point P shown by the arrow?

- A) Upwards on the page  
 B) Downwards on the page  
 C) To the right  
 D) To the left  
 E) Into the page  
 F) Out of the page



**Question 18:** The picture (below right) shows the trajectory of an electron, observed to move at a constant speed. This could be explained by

- A) A constant magnetic field pointing downward on the page  
 B) A constant magnetic field pointing into the page  
 C) A constant magnetic field pointing out of the page  
 D) A constant electric field pointing downward  
 E) A constant electric field pointing to the right

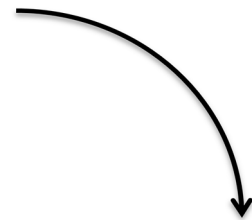

**Question 19:** A positively charged particle moves upward directly along the axis of a solenoid which carries a constant current. When the charge enters the magnetic field of the solenoid, it will

- A) Accelerate upward
- B) Accelerate downward
- C) Turn to the left
- D) Turn to the right
- E) Turn into the picture
- F) Turn out of the picture
- G) Continue traveling at constant velocity.

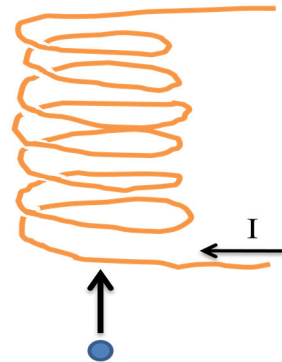

**Question 20:** The figure below shows four wire loops. All four loops move through a region of a uniform B-field at the same constant velocity. Rank the four loops, according to the *maximum* emf induced as they move through the field.

- A)  $c > b = d > a$
- B)  $c = d > a = b$
- C)  $a = d > c = b$
- D)  $c > d > b > a$
- E)  $a = b = c = d$ .

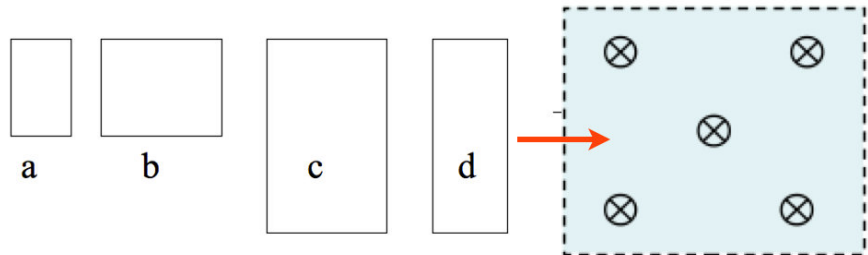

**Question 21:** The diagram to the right shows an electric field configuration. What can you say about the cause of this field? Choose the most complete answer.

(Hint: what current would this electric field induce in a circular wire?)

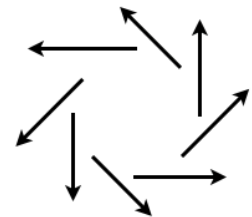

- A) It's caused by an increasing magnetic field pointing into the page.
- B) It's caused by a decreasing magnetic field pointing into the page.
- C) It's caused by an increasing magnetic field pointing out of the page.
- D) It's caused by a decreasing magnetic field pointing out of the page.
- E) a) and d) are both right
- F) a) and c) are both right
- G) b) and c) are both right
- H) b) and d) are both right

**Question 32:** Sketch a design for a simple electric motor and explain how it works.



**Question 35:**

A wire loop of mass  $M$ , area  $A$  and total resistance  $R$  rests at a distance  $x$  very far away from a bar magnet. At this distance we can assume that the magnetic field through the loop is essentially uniform, and the strength of the magnetic field is

$$B = \frac{\mu_0}{4\pi} \frac{2\mu}{x^3}$$

where  $\mu$  is the magnetic moment of the magnet (which is a constant). If the magnet is moved towards the loop at speed  $v$ , the loop is observed to move upward.

a) Explain why the loop moves upward.

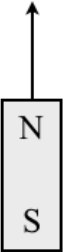

b) Determine the acceleration of the loop. For this part, it may be helpful to know that the force between two aligned magnetic dipoles separated by a distance  $x$  is:

$$F = \frac{3\mu_0 \mu_1 \mu_2}{2\pi x^4}$$

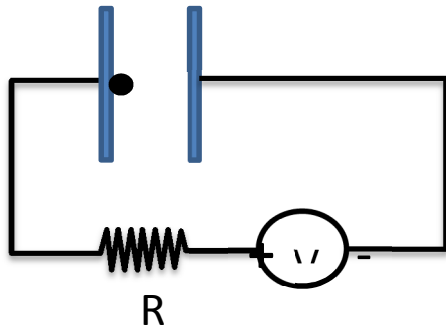

**Question 36:** A particle with mass  $M$  and positive charge  $Q$  starts at one side of a capacitor. The capacitor has two parallel plates of area  $A$  separated by a distance  $d$ . We would like to make the particle move to the right with a trajectory

$$x(t) = d \log(1 + t/T)$$

where  $T$  is a constant and  $d$  is still the distance between the plates. To achieve this, what voltage  $V(t)$  do we need to apply at the voltage source?



